

Name: Joe Churchwell
MASC: 0760
Course: CS556
Term: Spring 2013
Assignment: Lab 4 Part A
Description: Real-time simulator of a robot actuator

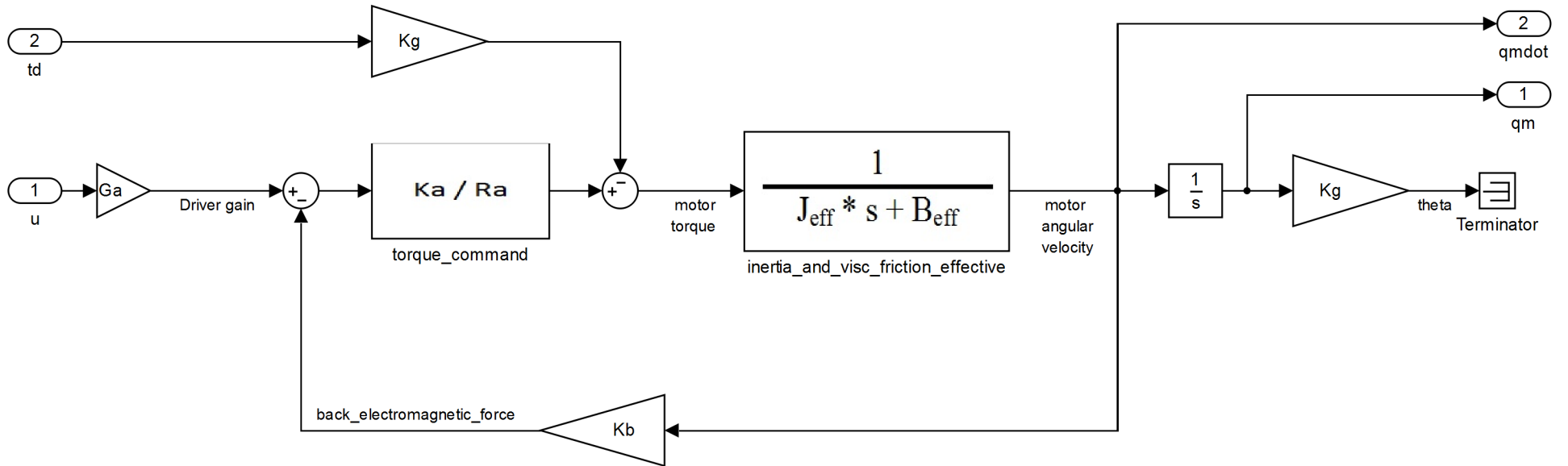

Name: Joe Churchwell
MASC: 0760
Course: CS556
Term: Spring 2013
Assignment: Lab 4 Part A
Description: Cycloid Robot Joint Controller

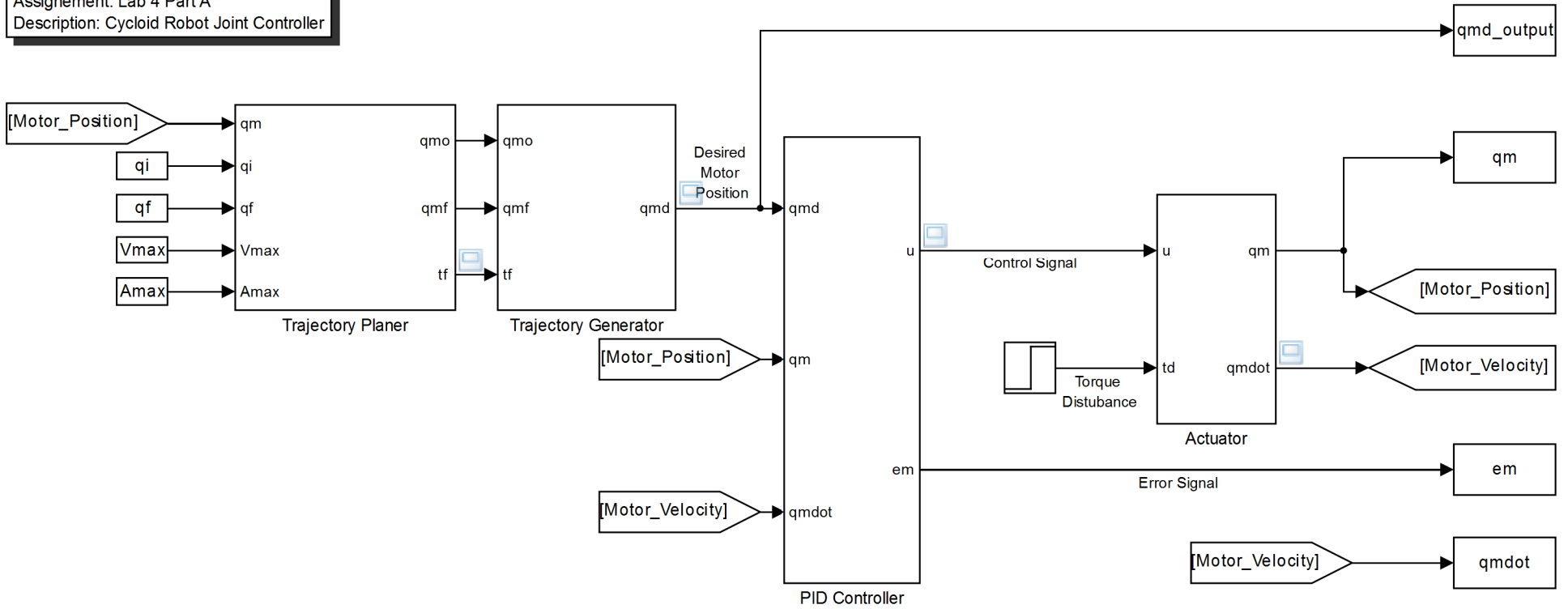

Name: Joe Churchwell
MASC: 0760
Course: CS556
Term: Spring 2013
Assignment: Lab 4 Part A
Description: PID Controller for Robot Actuator

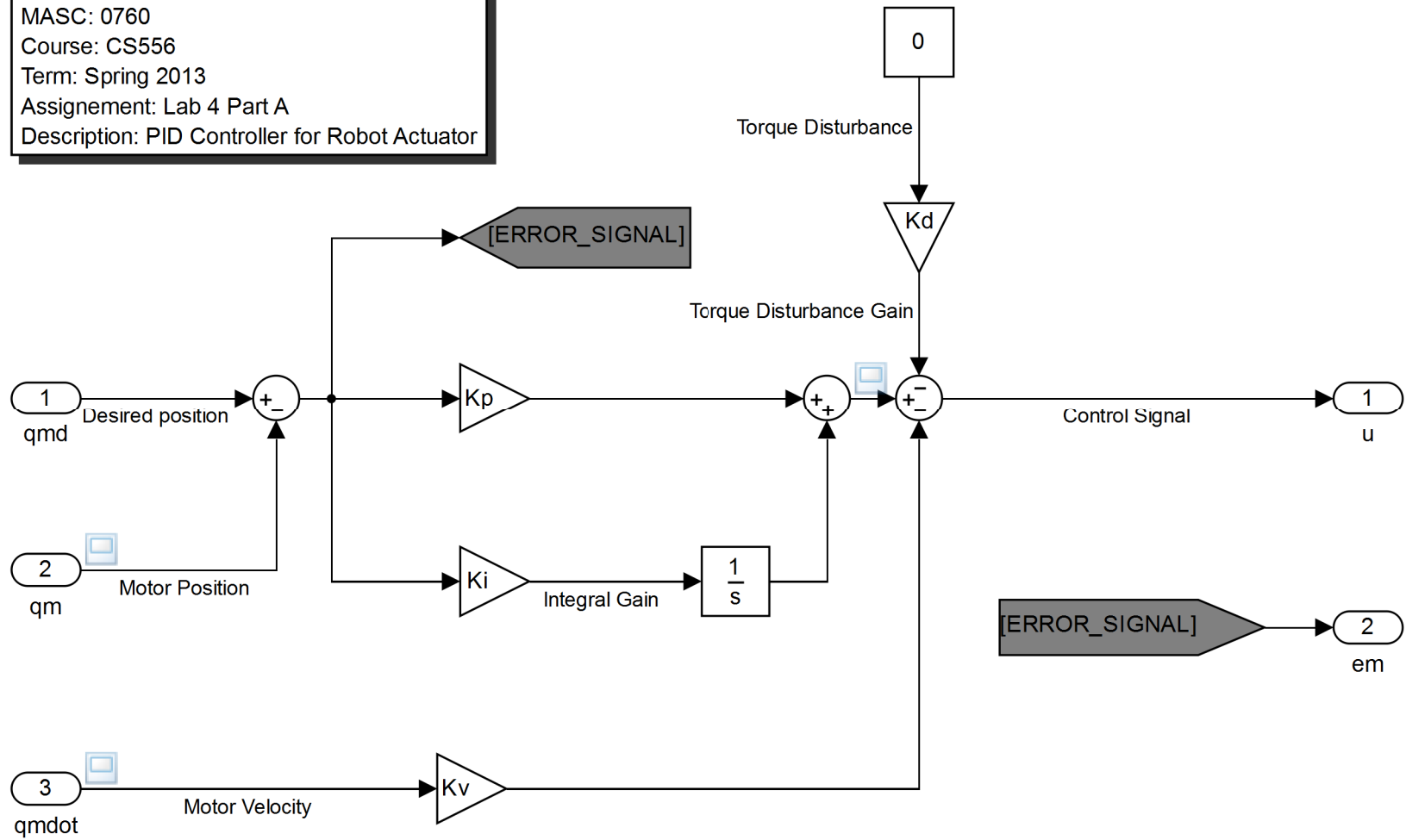

Name: Joe Churchwell
MASC: 0760
Course: CS556
Term: Spring 2013
Assignment: Lab 4 Part A
Description: Torque command for actuator

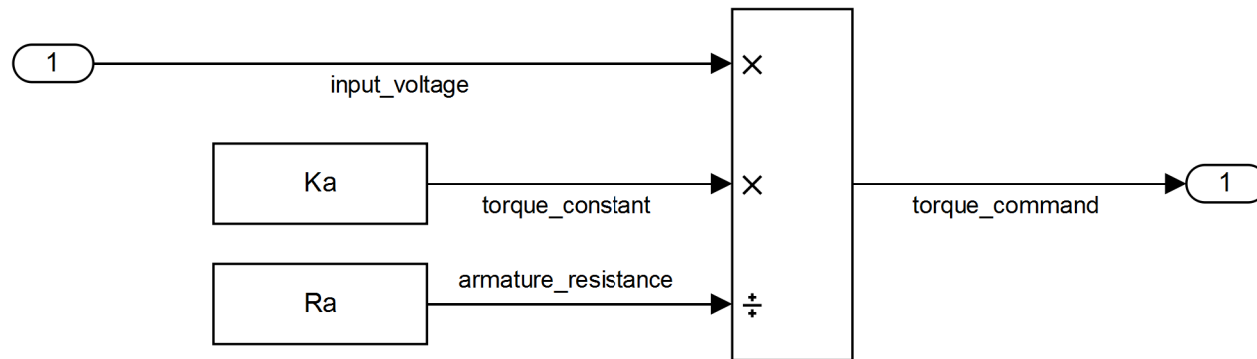

Name: Joe Churchwell
 MASC: 0760
 Course: CS556
 Term: Spring 2013
 Assignment: Lab 4 Part A
 Description: Trajectory Generator

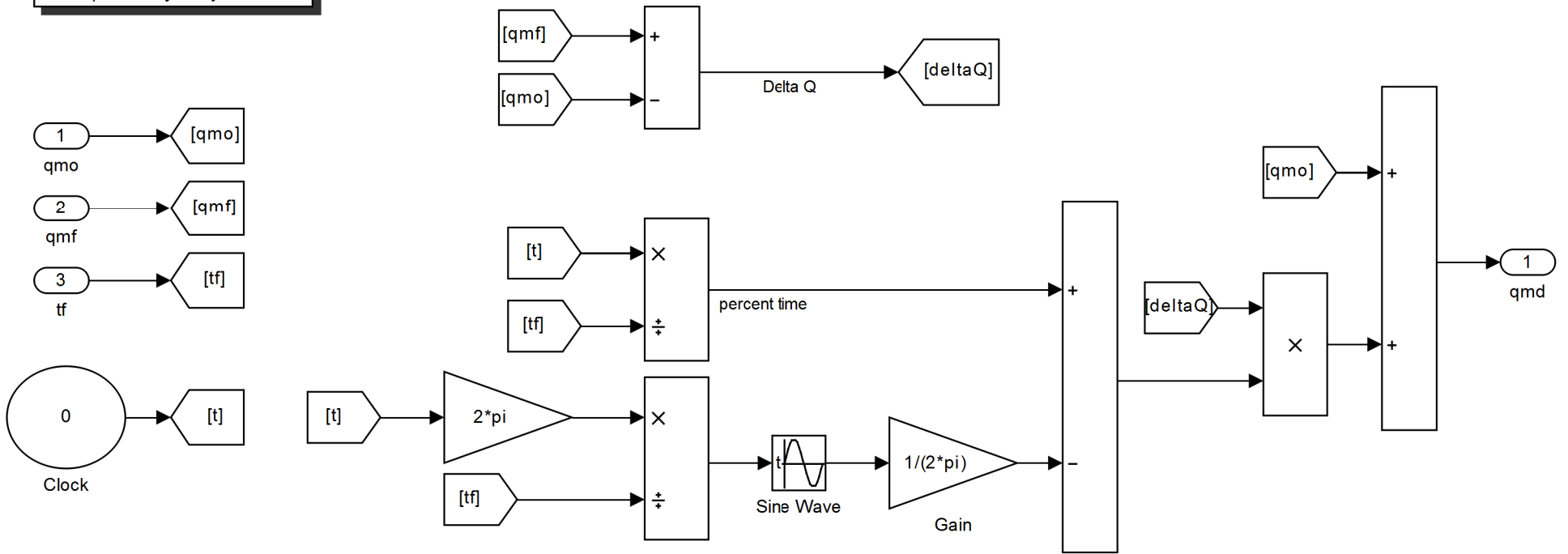

Name: Joe Churchwell
 MASC: 0760
 Course: CS556
 Term: Spring 2013
 Assignment: Lab 4 Part A
 Description: Trajectory Planner

